

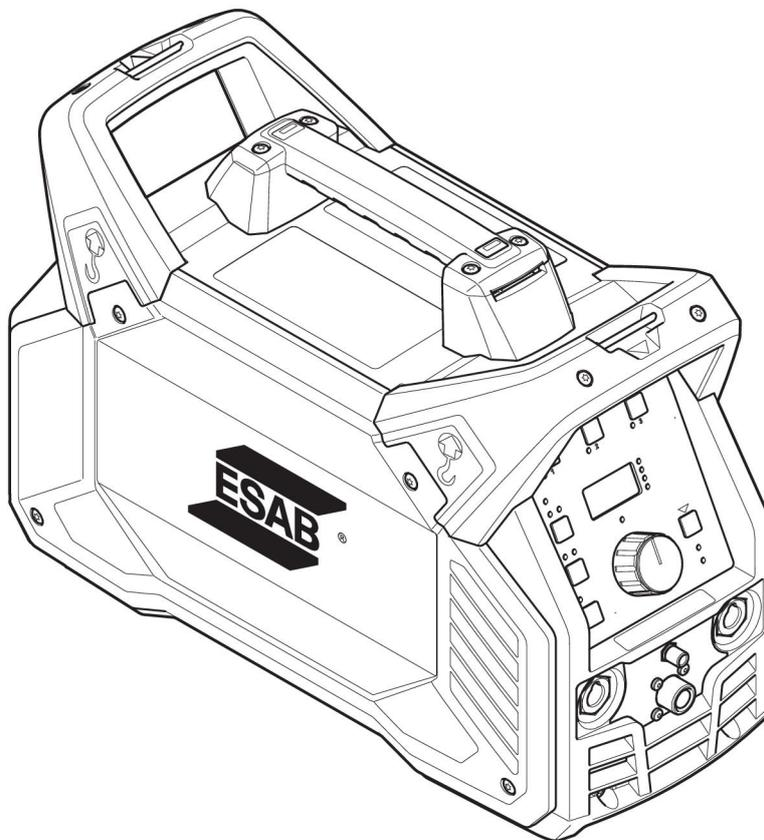

ET 300i, ET 300iP

Welding power source TIG 300 A

RENEGADE™



Instruction manual



EU DECLARATION OF CONFORMITY

According to
The Low Voltage Directive 2014/35/EU, entering into force 20 April 2016
The EMC Directive 2014/30/EU, entering into force 20 April 2016
The RoHS Directive 2011/65/EU, entering into force 2 January 2013

Type of equipment

Welding Power Source

Type designation

ET 300i, from serial number 714 xxx xxx (2017 w/14)

ET 300iP from serial number 714 xxx xxx (2017 w/14)

Brand name or trade mark

ESAB

Manufacturer or his authorised representative established within the EEA**Name, address, and telephone No:**

ESAB AB

Lindholmsallén 9, Box 8004, SE-402 77 Göteborg, Sweden

Phone: +46 31 50 90 00, Fax: +46 31 50 92 22

The following harmonised standard in force within the EEA has been used in the design:

EN 60974-1:2017, Arc Welding Equipment – Part 1: Welding power sources

EN 60974-3:2014, Arc Welding Equipment – Part 3: Arc striking and stabilizing devices

EN 60974-10:2014/AMD1:2015, Arc Welding Equipment – Part 10: Electromagnetic compatibility (EMC) requirements

Additional Information:

Restrictive use, Class A equipment, intended for use in location other than residential

By signing this document, the undersigned declares as manufacturer, or the manufacturer's authorised representative established within the EEA, that the equipment in question complies with the safety requirements stated above.

Date

Signature

Position

Gothenburg
2017-06-01

Stephen Argo

Global Director Equipment

CE 2017

1	SAFETY	5
1.1	Meaning of symbols	5
1.2	Safety precautions	5
2	INTRODUCTION	8
2.1	Overview	8
2.2	Equipment	8
3	TECHNICAL DATA	9
4	INSTALLATION	11
4.1	Location	11
4.2	Lifting instructions	11
4.3	Mains supply	12
4.4	Recommended fuse sizes and minimum cable area	15
5	OPERATION	17
5.1	Overview	17
5.2	Connections and control devices	17
5.3	TIG welding	18
5.4	MMA welding	18
5.5	Connection of welding and return cables	18
5.6	Turning the mains power on/off	18
5.7	Connect to cooler EC 1000	19
5.8	Fan control	19
5.9	Thermal protection	20
5.10	Voltage reducing device (VRD)	20
5.11	Remote control	20
5.12	USB connection	20
6	CONTROL PANEL	21
6.1	ET 300i	21
6.1.1	Navigation	21
6.1.2	Weld program	22
6.2	ET 300iP	23
6.2.1	Navigation	24
6.3	TIG settings	25
6.3.1	Hidden TIG functions	26
6.3.2	Measured values	26
6.4	TIG functions explanation	26
6.4.1	Foot pedal functions explanation	28
6.5	MMA settings	30
6.5.1	Hidden MMA functions	30
6.5.2	Measured values	26
6.6	MMA functions explanation	31

TABLE OF CONTENTS

7	MAINTENANCE	32
7.1	Routine maintenance	32
7.2	Cleaning instruction	32
8	TROUBLESHOOTING	36
9	ERROR CODES	37
9.1	Error code descriptions	37
10	ORDERING SPARE PARTS	39
	DIAGRAM	40
	ORDERING NUMBERS	41
	ACCESSORIES	42

1 SAFETY

1.1 Meaning of symbols

As used throughout this manual: Means Attention! Be Alert!



DANGER!

Means immediate hazards which, if not avoided, will result in immediate, serious personal injury or loss of life.



WARNING!

Means potential hazards which could result in personal injury or loss of life.



CAUTION!

Means hazards which could result in minor personal injury.



WARNING!

Before use, read and understand the instruction manual and follow all labels, employer's safety practices and Safety Data Sheets (SDSs).



1.2 Safety precautions

Users of ESAB equipment have the ultimate responsibility for ensuring that anyone who works on or near the equipment observes all the relevant safety precautions. Safety precautions must meet the requirements that apply to this type of equipment. The following recommendations should be observed in addition to the standard regulations that apply to the workplace.

All work must be carried out by trained personnel well-acquainted with the operation of the equipment. Incorrect operation of the equipment may lead to hazardous situations which can result in injury to the operator and damage to the equipment.

1. Anyone who uses the equipment must be familiar with:
 - its operation
 - location of emergency stops
 - its function
 - relevant safety precautions
 - welding and cutting or other applicable operation of the equipment
2. The operator must ensure that:
 - no unauthorised person is stationed within the working area of the equipment when it is started up
 - no-one is unprotected when the arc is struck or work is started with the equipment
3. The workplace must:
 - be suitable for the purpose
 - be free from drafts

4. Personal safety equipment:
 - Always wear recommended personal safety equipment, such as safety glasses, flame-proof clothing, safety gloves
 - Do not wear loose-fitting items, such as scarves, bracelets, rings, etc., which could become trapped or cause burns
5. General precautions:
 - Make sure the return cable is connected securely
 - Work on high voltage equipment **may only be carried out by a qualified electrician**
 - Appropriate fire extinguishing equipment must be clearly marked and close at hand
 - Lubrication and maintenance must **not** be carried out on the equipment during operation

**WARNING!**

Arc welding and cutting can be injurious to yourself and others. Take precautions when welding and cutting.

**ELECTRIC SHOCK - Can kill**

- Install and ground the unit in accordance with instruction manual.
- Do not touch live electrical parts or electrodes with bare skin, wet gloves or wet clothing.
- Insulate yourself from work and ground.
- Ensure your working position is safe

**ELECTRIC AND MAGNETIC FIELDS - Can be dangerous to health**

- Welders having pacemakers should consult their physician before welding. EMF may interfere with some pacemakers.
- Exposure to EMF may have other health effects which are unknown.
- Welders should use the following procedures to minimize exposure to EMF:
 - Route the electrode and work cables together on the same side of your body. Secure them with tape when possible. Do not place your body between the torch and work cables. Never coil the torch or work cable around your body. Keep welding power source and cables as far away from your body as possible.
 - Connect the work cable to the workpiece as close as possible to the area being welded.

**FUMES AND GASES - Can be dangerous to health**

- Keep your head out of the fumes.
- Use ventilation, extraction at the arc, or both, to take fumes and gases away from your breathing zone and the general area.

**ARC RAYS - Can injure eyes and burn skin**

- Protect your eyes and body. Use the correct welding screen and filter lens and wear protective clothing.
- Protect bystanders with suitable screens or curtains.

**NOISE - Excessive noise can damage hearing**

Protect your ears. Use earmuffs or other hearing protection.

MOVING PARTS - Can cause injuries



- Keep all doors, panels and covers closed and securely in place. Have only qualified people remove covers for maintenance and troubleshooting as necessary. Reinstall panels or covers and close doors when service is finished and before starting engine.



- Stop engine before installing or connecting unit.
- Keep hands, hair, loose clothing and tools away from moving parts.

FIRE HAZARD



- Sparks (spatter) can cause fire. Make sure that there are no inflammable materials nearby.
- Do not use on closed containers.

MALFUNCTION - Call for expert assistance in the event of malfunction.

PROTECT YOURSELF AND OTHERS!



CAUTION!

This product is solely intended for arc welding.



WARNING!

Do not use the power source for thawing frozen pipes.



CAUTION!

Class A equipment is not intended for use in residential locations where the electrical power is provided by the public low-voltage supply system. There may be potential difficulties in ensuring electromagnetic compatibility of class A equipment in those locations, due to conducted as well as radiated disturbances.

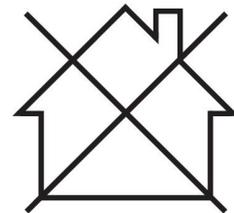

NOTE!

Dispose of electronic equipment at the recycling facility!

In observance of European Directive 2012/19/EC on Waste Electrical and Electronic Equipment and its implementation in accordance with national law, electrical and/or electronic equipment that has reached the end of its life must be disposed of at a recycling facility.

As the person responsible for the equipment, it is your responsibility to obtain information on approved collection stations.

For further information contact the nearest ESAB dealer.



ESAB has an assortment of welding accessories and personal protection equipment for purchase. For ordering information contact your local ESAB dealer or visit us on our website.

2 INTRODUCTION

2.1 Overview

The **ET 300i** and **ET 300iP** are welding power sources intended for TIG welding and for welding with covered electrodes (MMA).

ESAB accessories for the product can be found in the "ACCESSORIES" chapter of this manual.

2.2 Equipment

The power source is supplied with:

- Instruction manual
- 3 m (9.8 ft) mains cable with plug
- Gas hose for TIG welding, including hose clamps
- Return cable

3 TECHNICAL DATA

ET 300i (0445 100 900), ET 300iP (0445 100 920)		
Mains voltage	230–480 V $\pm 10\%$, 3~ 50/60 Hz	230 V $\pm 10\%$, 1~ 50/60 Hz
Mains supply $S_{SC \min}$	4.1 MVA	No demand
Z_{\max}	0.04 Ohm	No demand
Primary current		
I_{\max} MMA	30.0 A	29.0 A
I_{\max} TIG	22.0 A	20.0 A
No-load power demand when in the energy-saving mode		
U_{in} 230 V	63 W	74 W
U_{in} 400 V	68 W	
U_{in} 480 V	72 W	
Setting range		
MMA	5 A / 20 V - 300 A / 32 V	5 A / 20 V - 200 A / 28 V
TIG	5 A / 10 V - 300 A / 22 V	5 A / 10 V - 200 A / 18 V
Permissible load at MMA		
40% duty cycle	300 A / 32.0 V	
60% duty cycle	250 A / 30.0 V	
100% duty cycle	200 A / 28.0 V	200 A / 28.0 V
Permissible load at TIG		
40% duty cycle	300 A / 22.0 V	
60% duty cycle	250 A / 20.0 V	
100% duty cycle	200 A / 18.0 V	200 A / 18.0 V
Power factor at maximum current		
TIG	0.96	0.98
MMA	0.96	0.99
Apparent power I_2 at maximum current	11.6 kVA	6.6 kVA
Active power I_2 at maximum current	11.2 kW	6.6 kW
Efficiency at maximum current		
TIG	83%	83%
MMA	86%	86%
Open-circuit voltage U_0 max	48 V	48 V
Open-circuit voltage U_0 max with VRD 35 V activated	34 V	34 V
U_{PK}	12.4 kV	12.4 kV
Operating temperature	-10 to +40 °C (+14 to +104 °F)	

ET 300i (0445 100 900), ET 300iP (0445 100 920)	
Transportation temperature	-20 to +55 °C (-4 to +131 °F)
Continual sound pressure at no-load	< 70 db (A)
Dimensions l × w × h	460 × 200 × 320 mm (18.1 × 7.9 × 12.6 in.)
Weight with cooler	26.6 kg (58.6 lb)
without cooler	16.8 kg (37.0 lb)
Isolation class transformer	F
Enclosure class	IP23
Application class	S

Mains supply, $S_{sc \min}$

Minimum short circuit power on the network in accordance with IEC 61000-3-12.

Duty cycle

The duty cycle refers to the time as a percentage of a ten-minute period that you can weld or cut at a certain load without overloading. The duty cycle is valid for 40 °C / 104 °F, or below.

Enclosure class

The **IP** code indicates the enclosure class, i.e. the degree of protection against penetration by solid objects or water.

Equipment marked **IP23** is intended for indoor and outdoor use.

Application class

The symbol **S** indicates that the power source is designed for use in areas with increased electrical hazard.

4 INSTALLATION

The installation must be carried out by a professional.



CAUTION!

This product is intended for industrial use. In a domestic environment this product may cause radio interference. It is the user's responsibility to take adequate precautions.

4.1 Location

Position the power source so that its cooling air inlets and outlets are not obstructed.

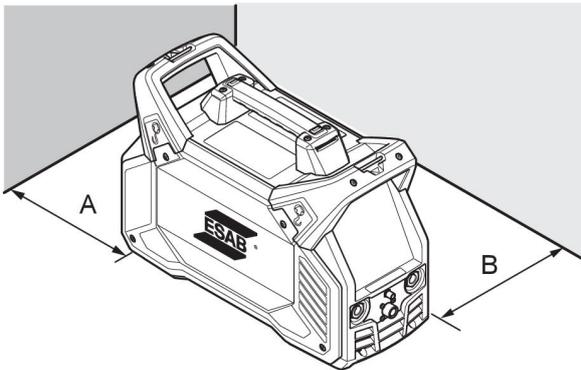

A. Minimum 200 mm (8 in.)

B. Minimum 200 mm (8 in.)



WARNING!

Secure the equipment - particularly if the ground is uneven or sloping.

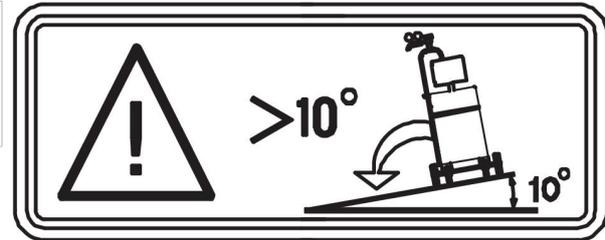

4.2 Lifting instructions

Mechanical lifting must be done with both outer handles.



4.3 Mains supply



NOTE!

Mains supply requirements

This equipment complies with IEC 61000-3-12 provided that the short-circuit power is greater than or equal to S_{scmin} at the interface point between the user's supply and the public system. It is the responsibility of the installer or user of the equipment to ensure, by consultation with the distribution network operator if necessary, that the equipment is connected only to a supply with a short-circuit power greater than or equal to S_{scmin} . Refer to the technical data in the TECHNICAL DATA chapter.

The power source will automatically adjust to the supplied input voltage; make sure it is protected by the correct fuse rating. A protective earth connection must be made, in accordance with regulations.

1. Rating plate with supply connection data

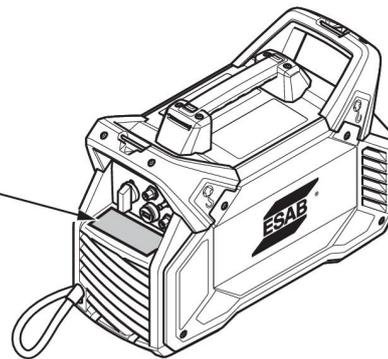

Installation of mains cable



NOTE!

The power source is delivered with a $4 \times 2.5 \text{ mm}^2$ mains cable and a 16 A mains plug which in combination can handle the rated data given for 3-phase 380–415 V mains supply. If other mains voltage is required, the mains cable may be changed according to relevant national regulations. For recommendations, see section Recommended fuse sizes and minimum cable area.

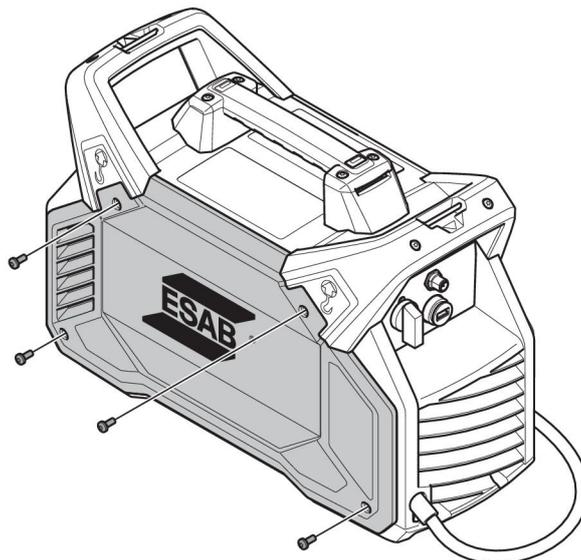

1. Remove the side panel.
2. If tightened, release the stopping block **(A)**.
3. If a cable is connected, disconnect all wires, cut the cable tie **(D)**, and remove the cable.
4. Optional: The fan with foam can at this point be removed to simplify the installation. Note the direction of the fan (the sticker towards the inside).
5. Strip the new wire according to specification **(B)**.
6. Insert the cable with about 1 cm (0.4 in.) of isolation inside the stopping block. Tighten the stopping block by using 1.5–2 Nm (13.3–17.7 in. lb) **(A)**.
7. Use two cable ties to fasten the cables **(D)**.
8. Optional: If the fan with foam has been removed it shall now be re-installed. A symbol on the side of the fan **(G)** shows the air flow direction.
9. Install the ferrites and connect the earth wire **(C)**. A toothed washer should be located closest to the heat sink. Tighten the screw to a torque of 6.0 ± 0.6 Nm (53.1 ± 5.3 in. lb).
10. Connect all wires in accordance with illustrations for 1-phase and 3-phase. Tighten the screw to a torque of 1.0 ± 0.2 Nm (8.9 ± 1.8 in. lb).
11. Ensure that the IP shield is correctly mounted on the inside of the side panel **(E)**.
12. Reassemble the side panel **(F)**.
13. Tighten the screws on the side panel with 3 ± 0.3 Nm (26.6 ± 2.7 in. lb).

3-phase

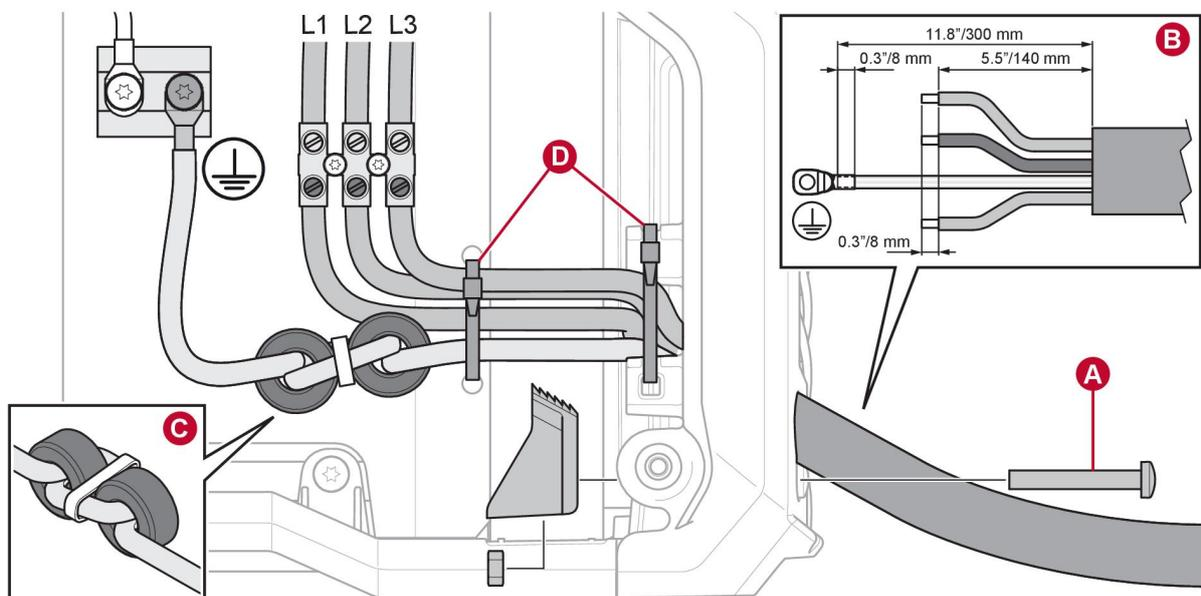

1-phase

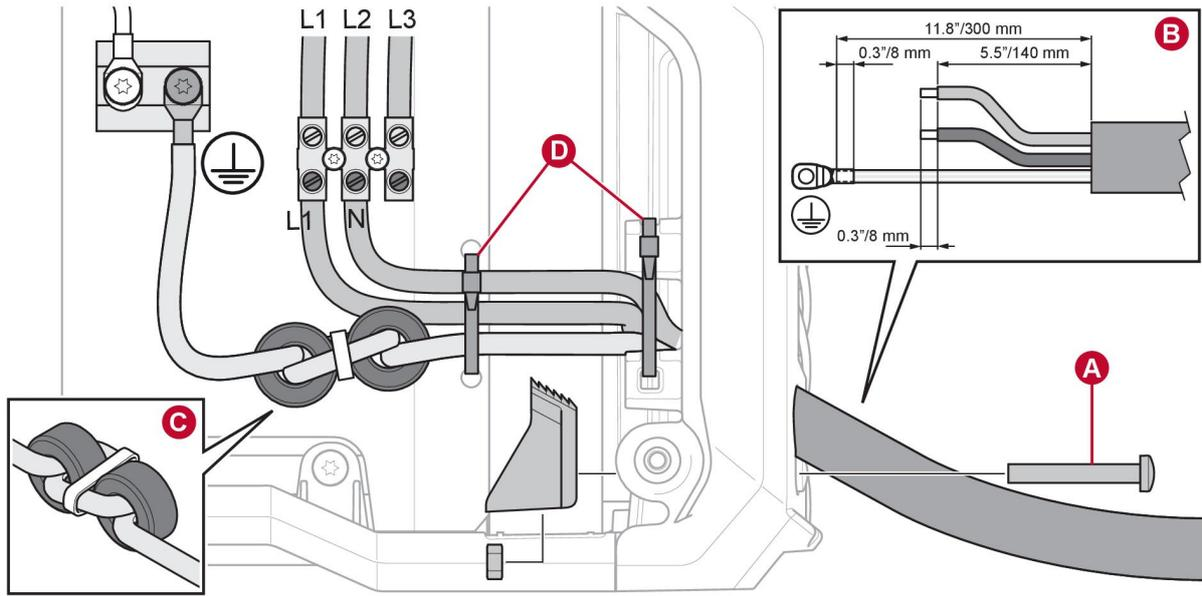

WARNING!

In 1-phase operation the terminal L3 is powered, even though not connected. Make sure to keep terminal L3 disconnected.

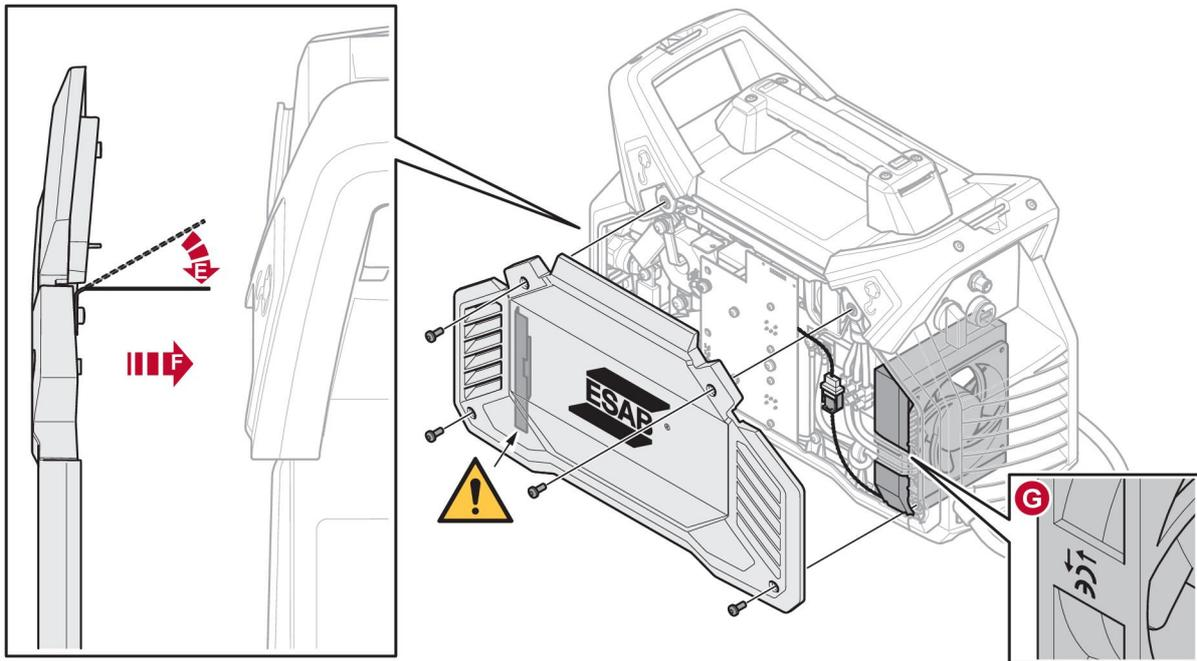

4.4 Recommended fuse sizes and minimum cable area

Recommended fuse sizes and minimum cable area

ET 300i, ET 300iPET 300i, ET 300iP						
3~ 50/60 Hz						1~ 50/60 Hz
Mains voltage	230 V	380 V	400 V	415 V	480 V	230 V
Mains cable area	4×4 mm ²	4×2.5 mm ²	4×2.5 mm ²	4×2.5 mm ²	4×2.5 mm ²	3×6 mm ²
Maximal current rating I_{\max} MMA	30 A	18 A	17 A	16 A	14 A	29 A
$I_{1\text{eff}}$ MMA	19 A	11 A	11 A	10 A	9 A	29 A
Maximal current rating I_{\max} TIG	22 A	13 A	12 A	12 A	10 A	20 A
$I_{1\text{eff}}$ TIG	14 A	8 A	8 A	7 A	7 A	16 A
Fuse anti-surge	20 A	16 A	16 A	16 A	10 A	35 A
type C MCB	25 A	16 A	16 A	16 A	16 A	32 A
Maximum recommended extension cord length	100 m/ 330 ft.	100 m/ 330 ft.	100 m/ 330 ft.	100 m/ 330 ft.	100 m/ 330 ft.	100 m/ 330 ft.
Minimum recommended extension cord size	4×4 mm ²	4×4 mm ²	4×4 mm ²	4×4 mm ²	4×4 mm ²	3×6 mm ²



NOTE!

Different variants of ET 300i and ET 300iP are certified for different mains voltage. Always refer to the rating plate for the specification of the power source in use.



NOTE!

The mains cable areas and fuse sizes as shown above are in accordance with Swedish regulations. Use the power source in accordance with the relevant national regulations.

1-phase 230 V mains voltage with 16 A mains fuse

See table below for informative data for use at 1-phase 230 V mains voltage with 16 A mains fuse. A 16 A mains fuse may enable the use of a 16 A mains plug in combination with a 3×2,5 mm² mains cable.

MMA 1~ 230 V 16 A			
	25%	60%	100%
I_2	200 A*	150 A	120 A
U_2	28.0 V	26.0 V	24.8 V

I_{\max}	28.2 A	20.2 A	15.3 A
I_{eff}	14.1 A	15.6 A	15.3 A
TIG 1~ 230 V 16 A			
		60%	100%
I_2		200 A*	170 A
U_2		18.0 V	16.8 V
I_{\max}		19.1 A	15.3 A
I_{eff}		14.8 A	15.3 A
*) Porcelain fuses are recommended to achieve 200 A in MMA and TIG mode. MCB fuses break the circuit faster than porcelain fuses.			

Supply from power generators

The power source can be supplied from different types of generators. However, some generators may not provide sufficient power for the welding power source to operate correctly. Generators with Automatic Voltage Regulation (AVR) or with equivalent or better type of regulation, with rated power 20 kW, are recommended.

5 OPERATION

5.1 Overview

General safety regulations for handling the equipment can be found in the chapter "Safety". Read it through before you start the equipment.



NOTE!

When moving the equipment use intended handle. Never pull the cables.



WARNING!

Electric shock! Do not touch the workpiece or the welding head during operation!

5.2 Connections and control devices

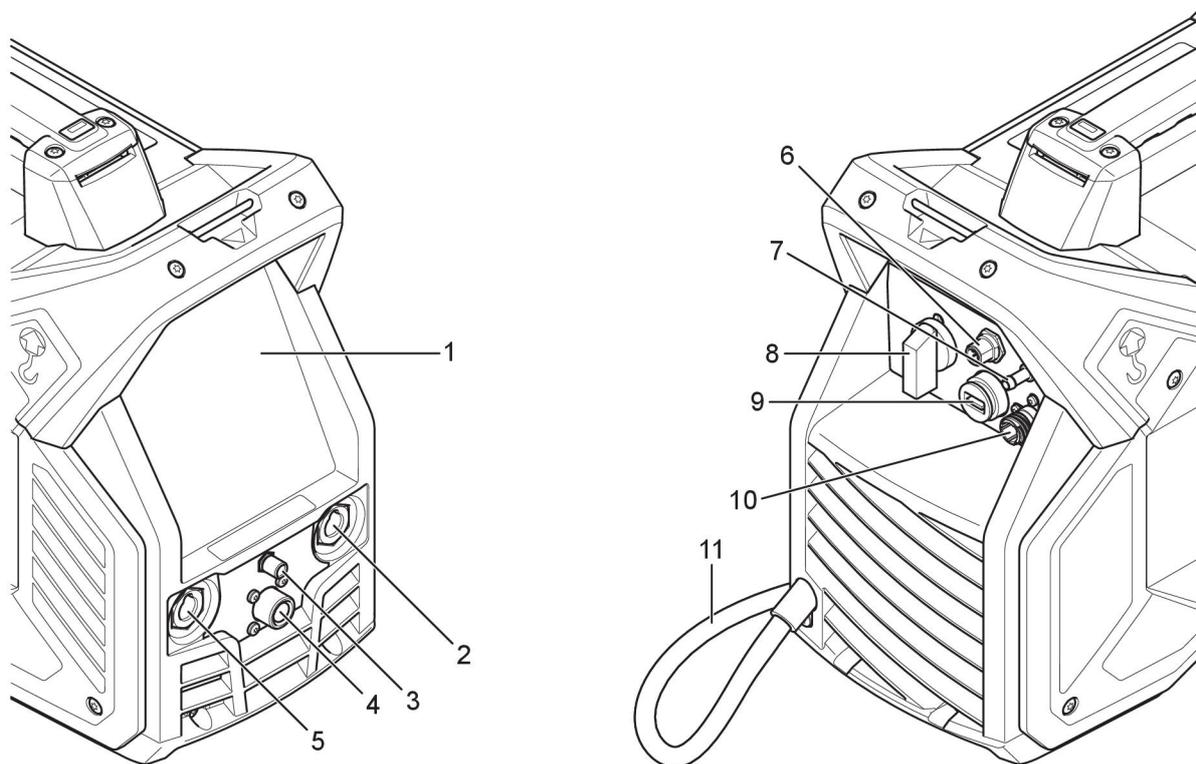

- | | |
|---|-----------------------------------|
| 1. User interface, see chapter CONTROL PANEL. | 7. Gas supply input |
| 2. Connection (+): TIG: Return cable MMA: Welding cable or return cable | 8. Mains power supply switch, O/I |
| 3. Gas supply output | 9. USB connection |
| 4. TIG torch trigger | 10. Connection for cooling unit |
| 5. Connection (-): TIG: torch MMA: Return cable or welding cable | 11. Mains cable |
| 6. Connection for remote control unit | |

**NOTE!**

When connecting a gas hose to the gas supply input, it must be secured using a hose clamp.

**NOTE!**

Always use the cover when the USB connection is not in use.

5.3 TIG welding



TIG welding melts the metal of the workpiece, using an arc initiated from a non-consuming tungsten electrode. The weld pool and electrode are protected by a shielding gas that usually consists of an inert gas.

For TIG welding, the welding power source shall be supplemented with:

- a TIG torch
- a gas hose connected to the gas supply input (using a hose clamp)
- an argon gas cylinder
- an argon gas regulator
- a tungsten electrode
- a return cable (with clamp)

5.4 MMA welding



MMA welding may also be referred to as welding with covered electrodes. The arc melts the electrode as well as a local part of the workpiece. The coverage, when melting, forms a protective slag and creates a shielding gas to protect the weld pool from atmospheric contamination.

For MMA welding the power source shall be supplemented with:

- welding cable with electrode holder
- return cable with clamp

5.5 Connection of welding and return cables

The power source has two outputs, a positive welding terminal (+) and a negative welding terminal (-), for connecting welding and return cables. The output to which the welding cable is connected depends on the welding method or type of electrode used.

Connect the return cable to the other output on the power source. Secure the return cable's contact clamp to the work piece and ensure that there is good contact between the work piece and the output for the return cable on the power source.

- For TIG welding, the negative welding terminal (-) is used for the welding torch and the positive welding terminal (+) is used for the return cable.
- For MMA welding, the welding cable can be connected to the positive welding terminal (+) or negative welding terminal (-) depending on the type of electrode used. The connecting polarity is stated on the electrode packaging.

5.6 Turning the mains power on/off

Turn on the mains power by turning switch to the "I" position.

Turn the unit off by turning the switch to the "O" position.

Whether the mains power supply is interrupted or the power source is switched off in the normal manner, weld programs will be stored so that it is available next time the unit is started.

**CAUTION!**

Do not turn off the power source during welding (with load).

5.7 Connect to cooler EC 1000

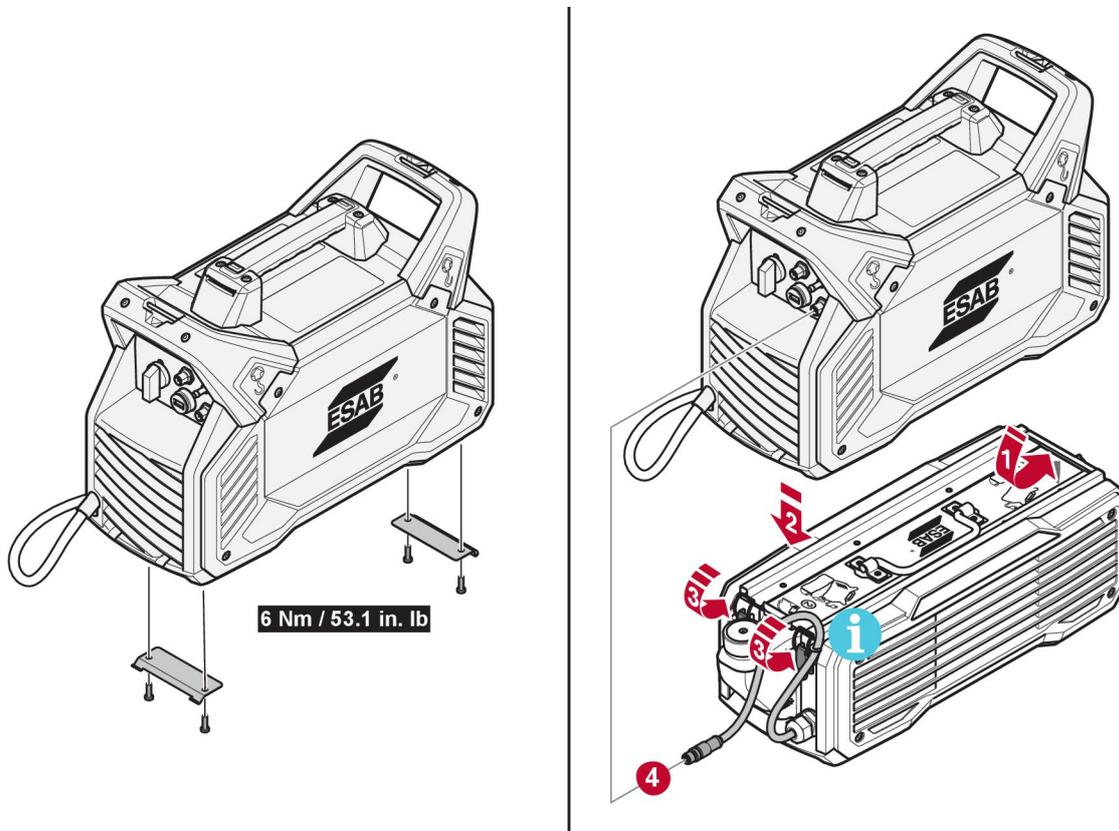
**NOTE!**

Take care so that the interface cable does not get squeezed between the power source and the cooling unit!

**NOTE!**

Power supply of the cooling unit is done from the welding power source via the connection cable (for more information, see the cooling unit instruction manual).

5.8 Fan control

The power source has an automatic thermal control. The fan continues to run during a few minutes after welding has stopped while the power source switches to energy-saving mode. The fan starts again when welding restarts.

During energy-saving mode the fan will start occasionally and run for a few minutes.

5.9 Thermal protection



The power source includes thermal protection against overheating. When overheating occurs the welding is stopped and overheating indicator on the panel will be lit and an error message shows in the display. The protection is automatically reset when the temperature has been sufficiently reduced.

5.10 Voltage reducing device (VRD)



The VRD function ensures that the open-circuit voltage does not exceed 35 V when welding is not being carried out. This is indicated by a lit VRD indicator on the panel. Contact an authorised ESAB service technician to activate this function.

5.11 Remote control



Connect the remote control on the rear side of the power source and activate the remote control by pressing the remote control button on the panel (remote control indicator being lit when activated). When the remote control is activated the control panel is locked for interaction but displays welding data.

5.12 USB connection



Always use the USB cover when the USB connection is not in use.

Do not use for charging units such as mobile phones.

The welding process is blocked when a USB flash drive is connected. The USB connection can be used to retrieve welding statistics. The statistics contains of total number of welds performed, total welding time and average current.

Retrieving welding statistics

Always make sure that the power source is not used for welding when retrieving welding statistics.

1. Insert an empty USB flash drive into the power source USB connector.
2. To confirm that the power source has read the USB flash drive, the text "USB" flashes in the display for a moment, after which the text "USB" is shown with fixed light.
3. When the text "USB" is shown with fixed light: Remove the USB flash drive from the USB connector.
4. The USB flash will contain a text file (.txt) with the welding statistics.
5. Recommended program for opening the text file is Microsoft WordPad or Microsoft Word.

6 CONTROL PANEL

6.1 ET 300i

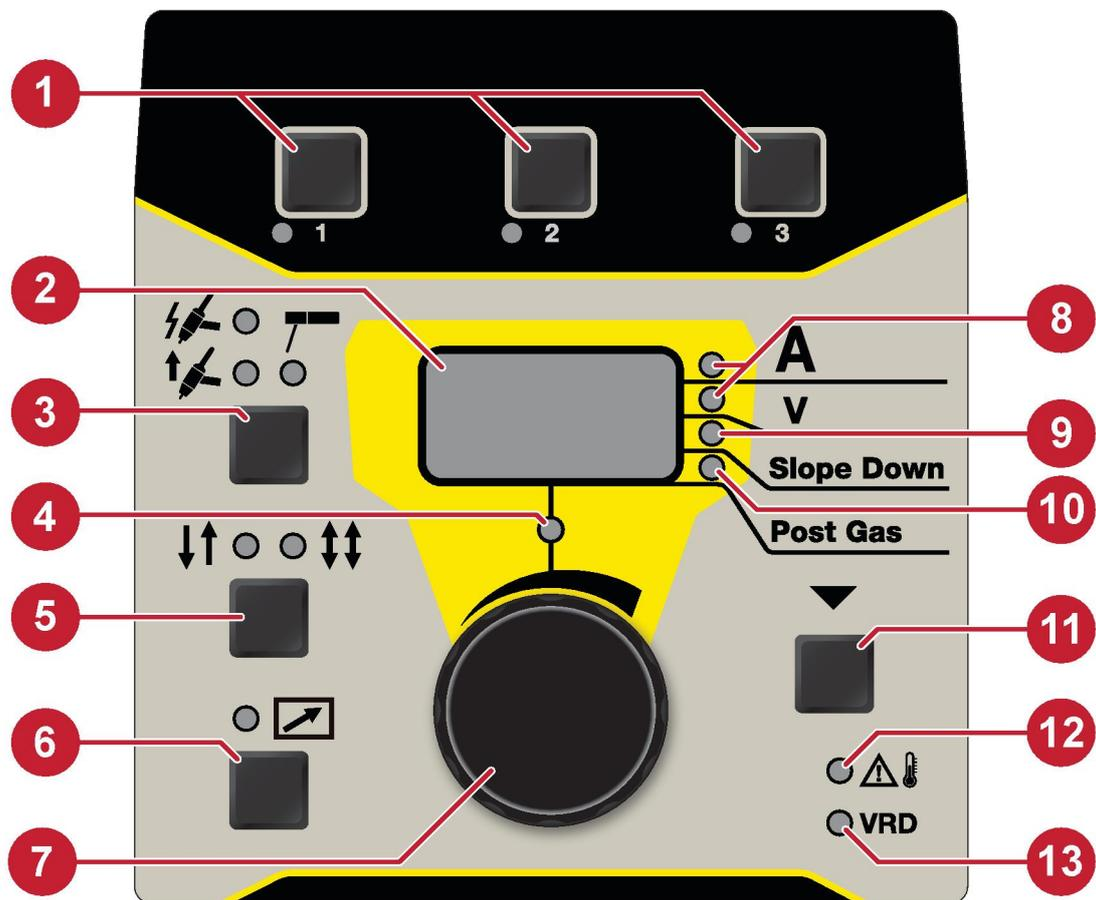

- | | |
|--|---|
| 1. Memory 1, 2 and 3. | 8. Current set and measure value / Voltage measure value |
| 2. Display, shows set or measured value. | 9. Slope down indicator. |
| 3. Button to select welding method: TIG HF, LiftArc™ or MMA. | 10. Gas post flow indicator. |
| 4. Set indicator. | 11. Parameter selection button, selection indicated by (8) to (10). Also used for access to hidden functions. |
| 5. Button to select 2-stroke or 4-stroke (TIG only). | 12. Overheating indicator. |
| 6. Button to activate and deactivate remote control unit. | 13. VRD function (reduced open-circuit voltage) indicator. |
| 7. Knob for setting data. | |

6.1.1 Navigation

Parameter selection

By pressing the button (11) different values can be shown. Use the knob (7) to change the values. The sequence is:

1. Set current value.
2. Measured current value.
3. Measured voltage value.
4. Slope down (TIG only)
5. Gas post flow (TIG only)

Set parameter

The set indicator (4) will be lit when the displayed value can be changed. It cannot be changed from the panel when a remote control is activated. Trying to change a value while in measured value mode will result in automatically move to set current value mode.

The set indicator is off when measured values are shown.

6.1.2 Weld program

For each welding process (MMA/TIG) three different weld programs can be stored in the setting panel memory (1). Press selection button 1, 2 or 3 for 3 seconds to store a weld program in the memory. The memory indicator will be lit when finished.

To switch between the different weld programs press button 1, 2 or 3.

6.2 ET 300iP

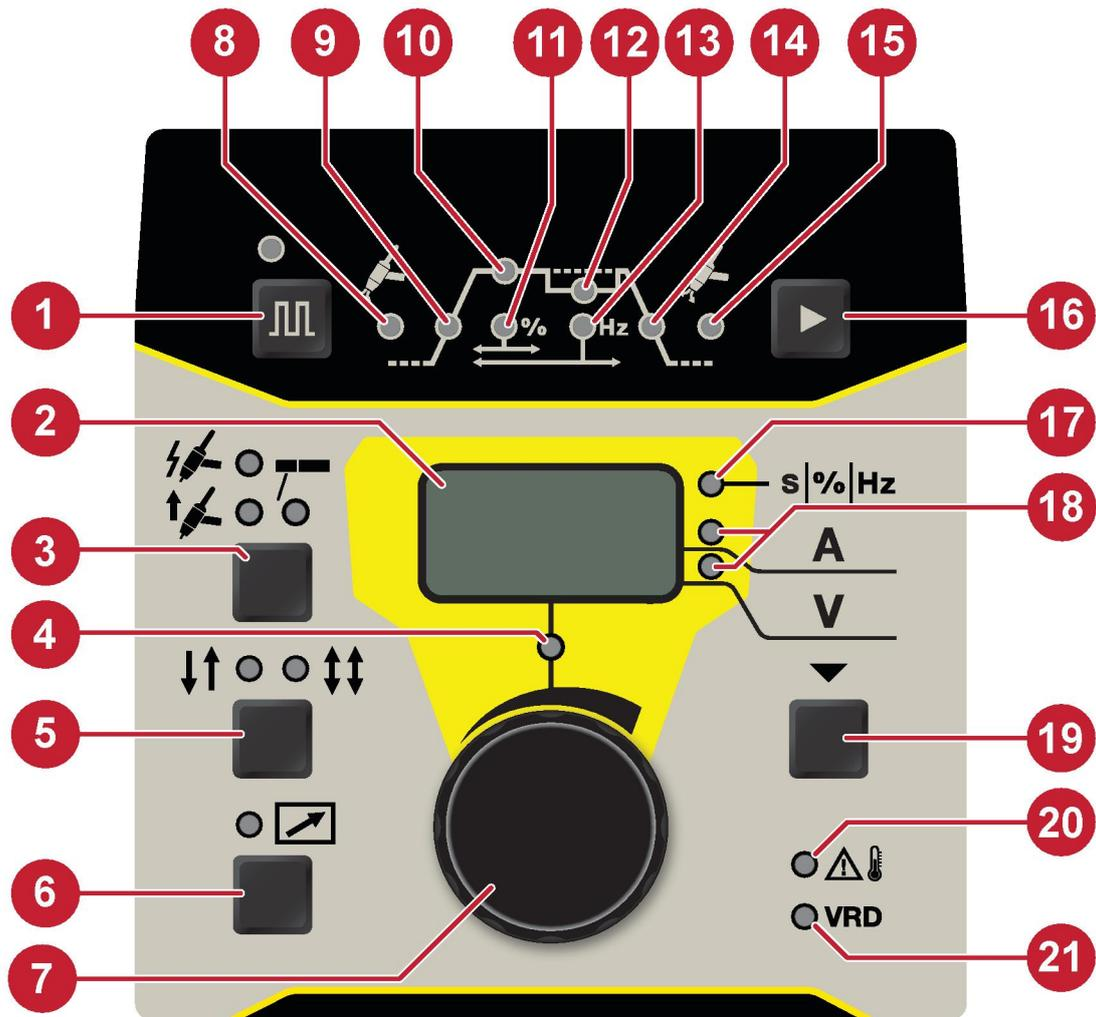

- | | |
|---|---|
| 1. Button to change between direct current and pulse current. | 12. Background current indicator. |
| 2. Display, shows set or measured value. | 13. Pulse frequency indicator. |
| 3. Button to select welding method: TIG HF, LiftArc™ or MMA. | 14. Slope down indicator. |
| 4. Set indicator. | 15. Gas post flow indicator. |
| 5. Button to select 2-stroke or 4-stroke (TIG only). | 16. Button to change between the parameters in the graph. |
| 6. Button to activate and deactivate remote control unit. | 17. Indicates which is shown in the display: s (seconds for gas pre flow, gas post flow, slope up and slope down), % (pulse balance), Hz (pulse frequency). |
| 7. Knob for setting data. | 18. Current set and measure value / Voltage measure value. |
| 8. Gas pre flow indicator. | 19. Parameter selection button, selection indicated by (18). Also used for access to hidden functions. |
| 9. Slope up indicator. | 20. Overheating indicator. |
| 10. Direct current or pulse current indicator. | 21. VRD function (reduced open-circuit voltage) indicator. |
| 11. Pulse balance. | |

6.2.1 Navigation

Parameter selection

By pressing the button (19) different values can be shown and changed. Use the knob (7) to change the values. The sequence is:

1. Set current value.
2. Measured current value.
3. Measured voltage value.

Set parameter

The set indicator (4) will be lit when a displayed value can be changed. It cannot be changed from the panel when a remote control is activated. Trying to change a value while in measured value mode will result in automatically move to set current value mode.

The set indicator (4) is off when measured values are shown.

Weld parameters

The weld parameters are stored for pulse and no pulse respectively. The values are changed when changing between pulse and no pulse.

6.3 TIG settings

Symbol	Function	Setting range	Setting steps	Default value	ET 300i	ET 300iP
	TIG HF*	ON/OFF		ON	X	X
	LiftArc*	ON/OFF		OFF	X	X
A	Current	1ph: 5–200 A 3ph: 5–300 A	1	100 A	X	X
	Slope up time	H: 0.0–9.9 s 0.0–25.0 s	0.1	1.5 s	H	X
	Slope down time	0.0–25.0 s	0.1	3.0 s	X	X
	Gas pre flow time	H: 0.0–9.9 s 0.0–25.0 s	0.1	1.0 s	H	X
	Gas post flow time	0.0–25.0 s	0.1	7.0 s	X	X
	2-stroke*	ON/OFF		ON	X	X
	4-stroke*	ON/OFF		OFF	X	X
	Remote control unit*	ON/OFF		OFF	X	X
	Pulse*	ON/OFF		OFF		X
	Pulse current	1ph: 5–200 A 3ph: 5–300 A		120 A		X
	Background current	1ph: 5–200 A 3ph: 5–300 A		80 A		X
	Pulse balance	10–90%	5	50%		X
	Pulse frequency	0.01–999 Hz	0.10–0.99: 0.01 1.0–9.9: 0.1 10–100: 1 100–300: 10 300–999: 100	100 Hz		X
	Remote min current	0–99%	1	20%	H	H
*) Parameter cannot be changed while welding					H = Hidden function	

6.3.1 Hidden TIG functions

There are hidden functions in the control panel. To access the functions, press parameter selection button for 3 seconds (see section SETTING PANEL for button placement). The display shows a letter and a value. Select function by pressing the same button. The knob is used to change the value of the selected function. To exit hidden functions, press the button for 3 seconds again.

Letter	Function	Settings
A	Gas pre flow	0.0–9.9 s
b	Slope up	0.0–9.9 s
l	Remote min current	0–99%

6.3.2 Measured values

A

Measured current

Measured value in the display for welding current A is arithmetic average value.

V

Measured voltage

Measured value in the display for arc voltage V is arithmetic average value.

6.4 TIG functions explanation



HF start

The HF start function initiates the arc by using a high frequency voltage pilot arc. This will reduce the risk of tungsten contamination in the starts. The high frequency voltage might disturb other electrical equipment in the surrounding area.



LiftArc™

The LiftArc™ function initiates the arc when the tungsten electrode is brought into contact with the workpiece, the trigger switch is pressed, and the tungsten electrode is lifted away from the workpiece. In order to minimize the risk of tungsten contaminations the start current is very low and will slope up to the set current (controlled by the slope up function).



2-stroke

In 2-stroke mode, press the TIG torch trigger switch (1) to start the shielding gas flow and initiate the arc. The current slopes up to the set current value. Release the trigger switch (2) to start to slope down the current and terminate the arc. The shielding gas will continue to flow in order to protect the weld and the tungsten electrode.

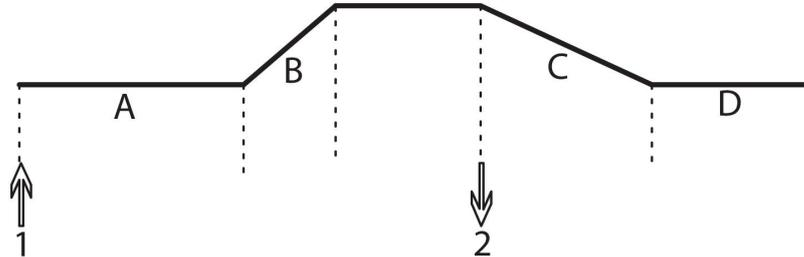

A = Gas pre flow

B = Slope up

C = Slope down

D = Gas post flow



4-stroke

In 4-stroke mode, press the TIG torch trigger switch (1) to start shielding gas flow and initiate the arc at a pilot level. Release the trigger switch (2) to slope up the current to the set current value. To stop the welding, press the trigger switch again (3). The current will slope down to the pilot level again. Release the trigger switch (4) to terminate the arc. The shielding gas will continue to flow in order to protect the weld and the tungsten electrode.

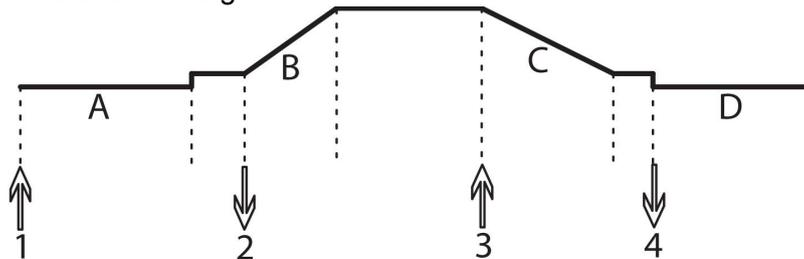

A = Gas pre flow

B = Slope up

C = Slope down

D = Gas post flow



Gas pre flow

The gas pre flow function controls the time during which shielding gas flows before the arc is initiated.



Gas post flow

The gas post flow function controls the time during which shielding gas flows after the arc is terminated.

Slope up

The slope up function is used to control the time of the current increase in the weld initiation process to avoid any possible damage to the tungsten electrode.

Slope down

The slope down function is used to control the time of the current decrease in the weld termination process to avoid any pipes and/or cracks.

**Pulse settings**

In order to set a pulsed current, four parameters are required: pulse current, background current, pulse balance and pulse frequency.

Pulse current

The higher of the two current values when using a pulsed current.

Pulse background current

The lower of the two current values when using a pulsed current.

Pulse balance

Pulse balance is the ratio between pulse current and background current in a pulse cycle. In order to control the energy of the arc and the size of the weld pool, pulse balance is adjustable by setting the percentage of the pulse current in a pulse cycle.

For example: If the pulse balance is set to 50%, the time of the pulse current and the background current will be distributed equally in the pulse cycle. If the pulse balance is set to 90%, the time of the pulse current will be 90% of the pulse cycle and the background current will only be 10%.

Pulse frequency

The amount of pulse cycles in a time period. The higher the frequency, the more pulse cycles per time period. When the pulse frequency is set low, the weld pool will have time to partially solidify between each pulse. If the frequency is set high, a more focused arc can be obtained.

Remote min current

This is used to set the minimum current for the foot pedal. Is set in % of the set current in the range from 0–99% in steps of 1%.

For example: If the current is set to 100 A and the remote min current function is set to 20, the remote min current will be 20 A. If the current is set to 80 A and the remote min current function is set to 50, the remote min current will be 40 A.

6.4.1 Foot pedal functions explanation**Foot pedal with 2-stroke using TIG torch trigger**

In 2-stroke mode, with the foot pedal activated, press the TIG torch trigger switch (1) to start the shielding gas flow and initiate the arc. The current slopes up to the set remote min current. Use the foot pedal to adjust the current between the remote min current and the set current value. Release the TIG torch trigger switch (2) to start to slope down the current and terminate the arc. The shielding gas will continue to flow in order to protect the weld and the tungsten electrode.

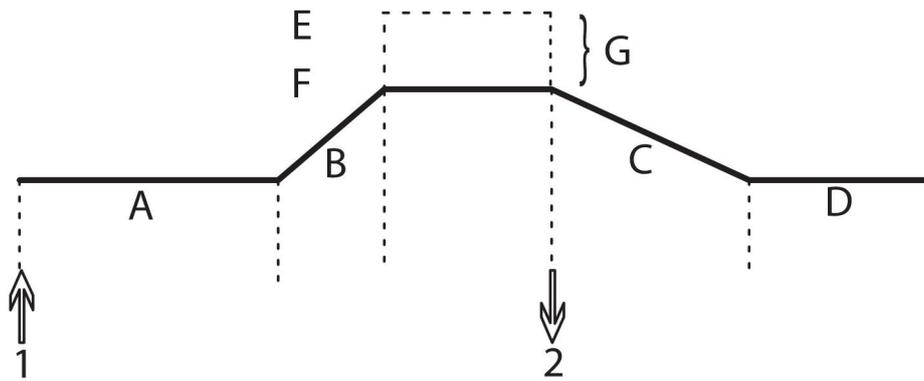

A = Gas pre flow

B = Slope up

C = Slope down

D = Gas post flow

E = Set current

F = Remote min current

G = Current range adjustable by the foot pedal

Foot pedal with 4-stroke using TIG torch trigger

In 4-stroke mode, with the foot pedal activated, press the TIG torch trigger switch (1) to start the shielding gas flow and initiate the arc at a pilot level. Release the trigger switch (2) to slope up the current to the remote min current. Use the foot pedal to adjust the current between the remote min current and the set current value. To stop the welding, press the trigger switch again (3). The current will slope down to the pilot level again. Release the trigger switch (4) to terminate the arc. The shielding gas will continue to flow in order to protect the weld and the tungsten electrode.

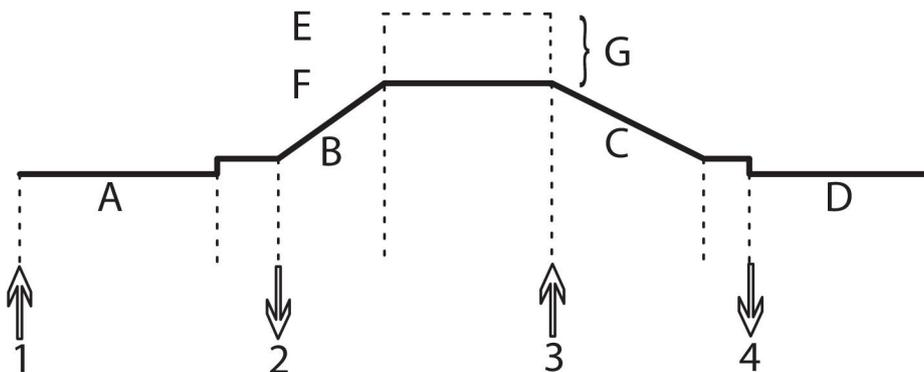

A = Gas pre flow

B = Slope up

C = Slope down

D = Gas post flow

E = Set current

F = Remote min current

G = Current range adjustable by the foot pedal

Foot pedal

Press down the foot pedal (1) to start the shielding gas flow and initiate the arc. The current slopes up to the set remote min current. Use the foot pedal to adjust the current between the remote min current and the set current value. Release the foot pedal to start to slope down the current and to terminate the arc. The shielding gas will continue to flow in order to protect the weld and the tungsten electrode.

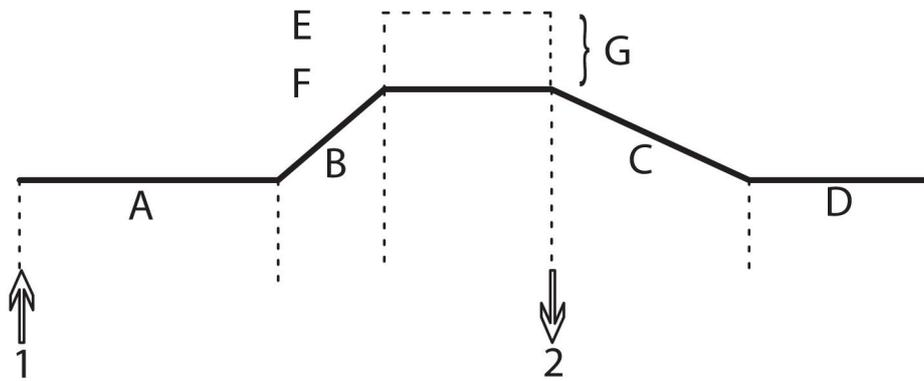

A = Gas pre flow

B = Slope up

C = Slope down

D = Gas post flow

E = Set current

F = Remote min current

G = Current range adjustable by the foot pedal

6.5 MMA settings

Symbol	Function	Setting range	Setting steps	Default value	ET 300i	ET 300iP
	MMA*	ON/OFF		ON	X	X
A	Current	1ph: 5–200 A 3ph: 5–300 A	1	100 A		
	Arc force	0–99	1	50	H	H
	Hot start	0–99%	1	20%	H	H
	Remote control unit*	ON/OFF		OFF	X	X
*) Parameter cannot be changed while welding					H = Hidden function	

6.5.1 Hidden MMA functions

There are hidden functions in the control panel. To access the functions, press parameter selection button for 3 seconds (see section SETTING PANEL for button placement). The display shows a letter and a value. Select function by pressing the same button. The knob is used to change the value of the selected function. To exit hidden functions, press the button for 3 seconds again.

Letter	Function	Settings
C	Arc force	0–99
H	Hot start	0–99%

6.5.2 Measured values

A

Measured current

Measured value in the display for welding current A is arithmetic average value.

V

Measured voltage

Measured value in the display for arc voltage V is arithmetic average value.

6.6 MMA functions explanation

Arc force

The arc force function determines how the current changes in response to variations in arc length during welding. Use a low value of arc force to get a calm arc with little spatter and use a high value to get a hot and digging arc.

Arc force only applies to MMA welding.

Hot start

The hot start function temporarily increases the current in the beginning of the weld, thus reducing the risk of lack of fusion in the starting point.

Hot start only applies to MMA welding.

7 MAINTENANCE



WARNING!

Disconnect power before performing maintenance.



CAUTION!

Only persons with the appropriate electrical knowledge (authorised personnel) may remove safety plates.



CAUTION!

The product is covered by manufacturer's warranty. Any attempt to carry out repair work by non-authorised service centers will invalidate the warranty.



NOTE!

Regular maintenance is important for safe and reliable operation.



NOTE!

Perform maintenance more often during severe dusty conditions.

Before each use - make sure that:

- Product and cables are not damaged,
- The torch is clean and not damaged.

7.1 Routine maintenance

Maintenance schedule during normal conditions. Check equipment prior to every use.

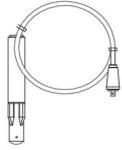
Interval	Area to maintain		
Every 3 month	 Clean or replace unreadable labels.	 Clean weld terminals.	 Check or replace weld cables.
Every 6 month	 Clean inside equipment. Use dry compressed air with reduced pressure.		

7.2 Cleaning instruction

To maintain the performance and increase the lifetime of the power source it is mandatory to clean it regularly. How often depends on:

- the welding process
- the arc time
- the working environment



CAUTION!

Make sure that the cleaning procedure is done in a suitable prepared workspace.



CAUTION!

During cleaning, always wear recommended personal safety equipment, such as ear plugs, safety glasses, masks, gloves and safety shoes.

1. Disconnect the power source from the mains supply.



WARNING!

Wait at least 30 seconds for the capacitors to discharge before continuing.

2. Remove the four screws holding the right side panel (**R**) and remove the panel.

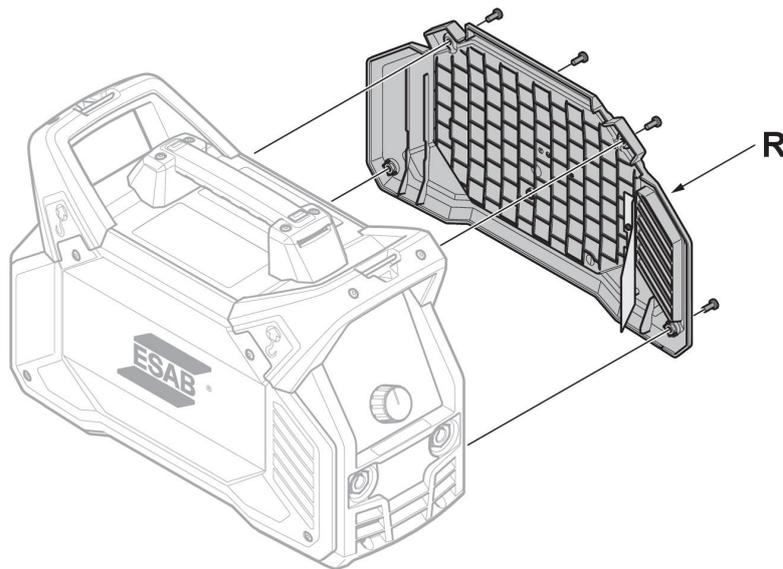

3. Clean the right side of the power source, using dry compressed air with reduced pressure.



NOTE!

Since the power source contains one "dirty side" (the right side) and one "clean side" (the left side), it is important that you do not remove **the left** side panel before cleaning the right side of the power source.

4. Remove the four screws holding the left side panel (L) and remove the panel.

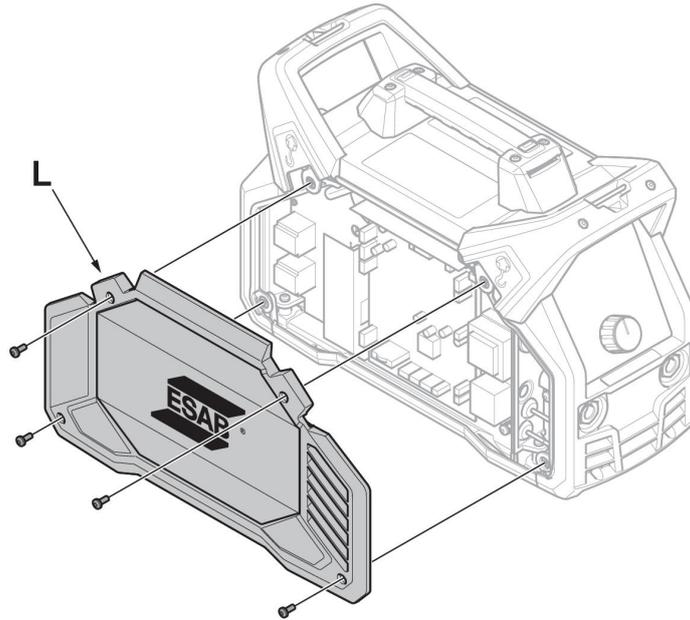

5. Clean the left side of the power source, using dry compressed air with reduced pressure.
6. Make sure that there is no dust left on any part of the power source.
7. After having finished cleaning the power source, reattach the power source panels in the reverse order.



NOTE!

When reattaching the right side panel, make sure the IP shield on the inside of the panel is in the correct position. The IP shield should be angled approximately 90° into the power source, so that it is positioned between the welding outlet connector and the transformer outlets.

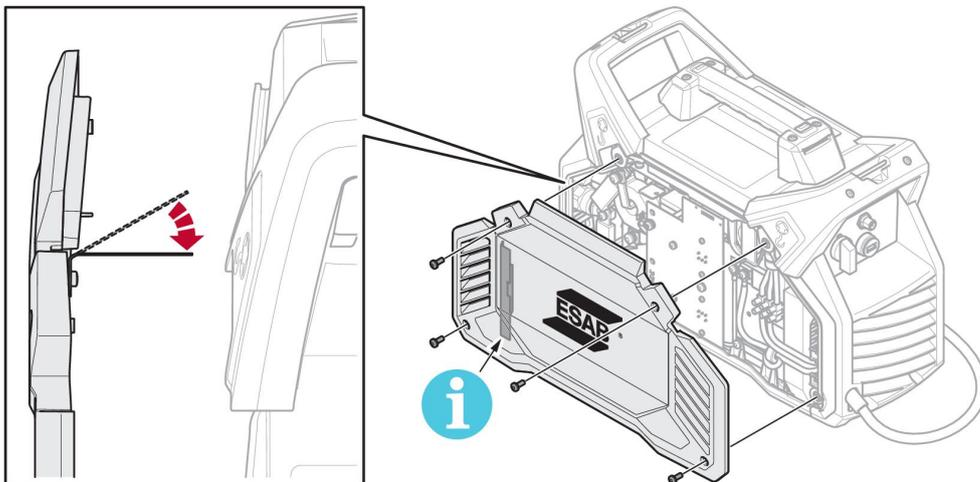

8. Tighten the screws on the side panels with $3 \text{ Nm} \pm 0.3 \text{ Nm}$ ($26.6 \text{ in lb.} \pm 2.6$).

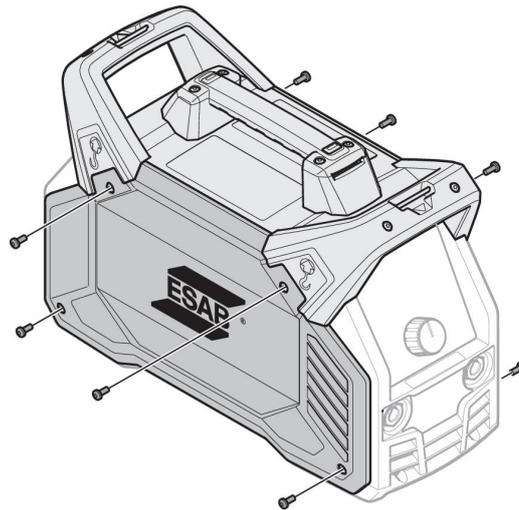

8 TROUBLESHOOTING

Perform these checks and inspections before sending for an authorised service technician.

Type of fault	Corrective action
MMA welding problems	<ul style="list-style-type: none"> • Check that the welding and return cables are not damaged and that they are correctly connected to the power source. • Make sure the return clamp has proper contact with the work piece. • Check that the correct electrodes and polarity are being used. For polarity, check electrode packaging. • Check that the correct current value is set. • Adjust Arc Force and Hot start.
TIG welding problems	<ul style="list-style-type: none"> • Check that the welding and return cables are not damaged and that they are correctly connected to the power source. • Make sure the return clamp has proper contact with the work piece. • Make sure the TIG torch lead is connected to negative welding terminal. • Make sure the correct shielding gas, gas flow, welding current, filler rod placement, electrode diameter and welding mode on power source is used. • Make sure the gas valve on the TIG torch is on.
No arc	<ul style="list-style-type: none"> • Check that display is on to verify that the power source has power. • Check setting panel display correct values. • Check that the mains power supply switch is turned on. • Check that the mains, welding and return cables are correctly connected. • Check the mains power supply fuses.
Welding current is interrupted during welding	<ul style="list-style-type: none"> • Check whether the overheating light (thermal protection) at setting panel is on. • Continue with fault type "No Arc".
The thermal protection trips frequently	<ul style="list-style-type: none"> • Make sure the recommended duty cycle for the weld current has not been exceeded. See section "Duty cycle" in the TECHNICAL DATA chapter. • Make sure the air inlets or outlets are not clogged. • Clean inside machine according to routine maintenance. • Check and clean the cooler.
The maximum current setting is limited to 200 A	<ul style="list-style-type: none"> • Check that the power source is connected to 3-phase mains power supply. • Check the mains power supply fuses.

9 ERROR CODES

The error code is used to indicate that a fault has occurred in the equipment. Errors are indicated by the text "Err" followed by the error code number shown in the display.

If several errors have been detected only the code for the last occurring error is displayed.

9.1 Error code descriptions

Error codes that the user can handle are listed below. If any other error code appears, contact an authorised ESAB service technician.

Error code	Description
Err 1	<p>Temperature fault The temperature of the power source is too high. A LED indicating temperature fault is also lit on the panel. A temperature fault is indicated by the overheating indicator on the control panel.</p> <p>Action: The error code will automatically disappear and the LED indicating temperature fault will be turned off when the power source has cooled down and is ready for use again. If the error persists, contact a service technician.</p>
Err 2	<p>Coolant fault The temperature of the coolant fluid is too high.</p> <p>Action: Make sure that there is sufficient coolant fluid in the cooler. The error code will automatically disappear when the coolant has cooled down and is ready for use again. If the error persists, contact a service technician.</p>
Err 3	<p>Power supply fault The power supply to the power source is too low or too high.</p> <p>One phase is lost during 3-phase operation. Third phase voltage detected during 1-phase operation.</p> <p>Action: Make sure the power supply is stable, all leads are connected, that the mains voltage (all 3 phases) are OK and restart the system. If the error persists, contact a service technician.</p>
Err 4	<p>Communication fault The communication between units has been disrupted.</p> <p>Action: Check cables and connections, restart the power source. If the error persists, contact a service technician.</p>
Err 5	<p>Memory fault The program memory is damaged. This fault can disable preset functions or other functions where values are stored.</p> <p>Action: Remove the error indication from the display by pressing a button on the panel. Restart the power source. If the error persists, contact a service technician.</p>
Err 6	<p>Timing fault The power source electronics are not able to execute all functions in a timely fashion.</p> <p>Action: Restart the power source. If the error persists, contact a service technician.</p>

Error code	Description
Err 7	OCV fault The OCV is too high or the electronic control of the OCV has been disrupted. Action: Restart the power source. If the error persists, contact a service technician.
Err 8	Water cooling disabled The hose from the torch is not connected to the cooling unit. Action: If a water cooled torch is used make sure it is connected to the cooling unit. If a water cooled torch is not used, press a button on the control panel to cancel the error. If the error persists, contact a service technician.

10 ORDERING SPARE PARTS



CAUTION!

Repair and electrical work should be performed by an authorised ESAB service technician. Use only ESAB original spare and wear parts.

The ET 300i and ET 300iP are designed and tested in accordance with international and european standards **IEC/EN 60974-1**, **IEC/EN 60974-3** and **IEC/EN 60974-10**, Canadian standards **CAN/CSA-E60974-1** and US standards **ANSI/IEC 60974-1**. On completion of service or repair work, it is the responsibility of the person(s) performing the work to ensure that the product still complies with the requirements of the above standard.

Spare parts and wear parts can be ordered through your nearest ESAB dealer, see the back cover of this document. When ordering, please state product type, serial number, designation and spare part number in accordance with the spare parts list. This facilitates dispatch and ensures correct delivery.

DIAGRAM

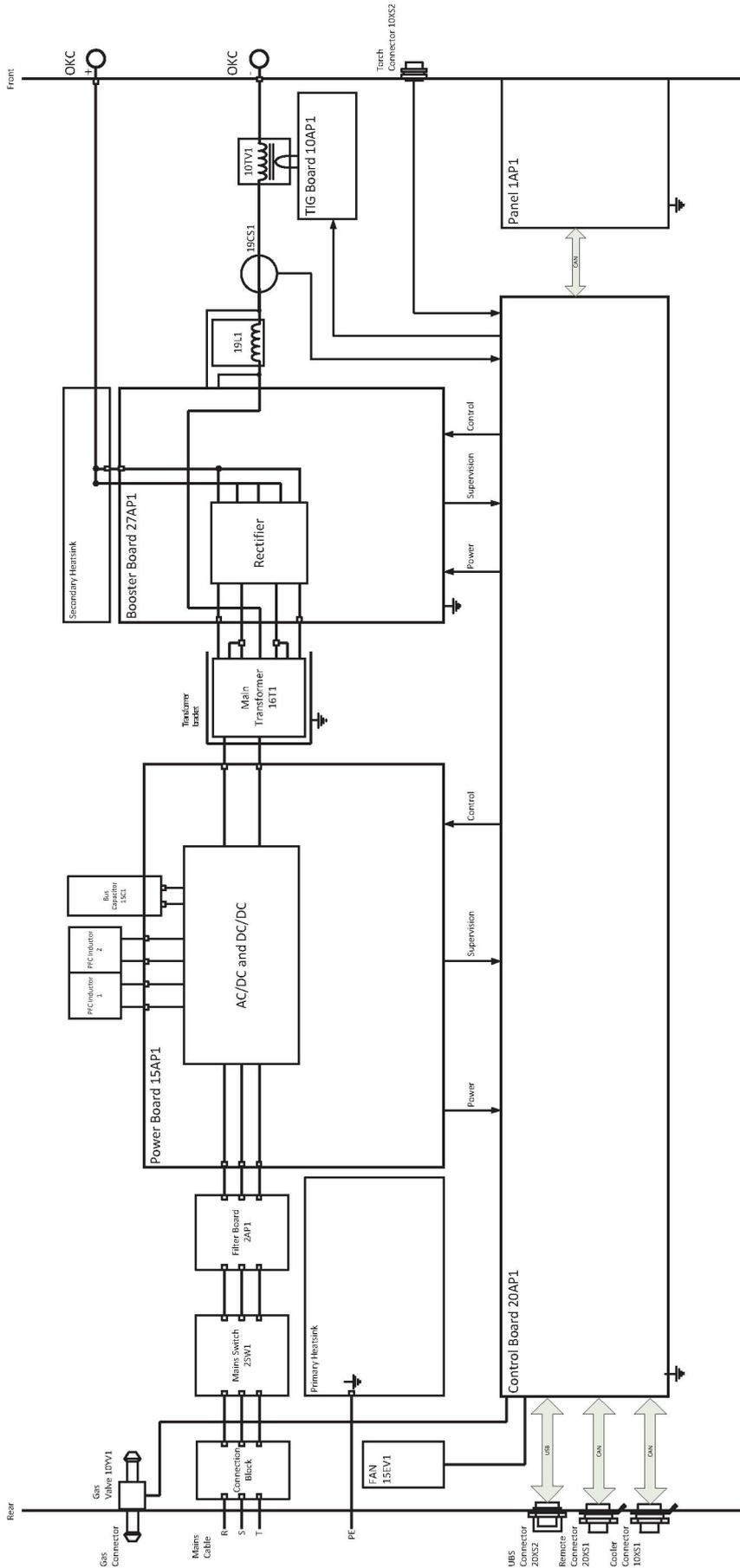

ORDERING NUMBERS



Ordering number	Denomination	Type	Notes
0445 100 900	Welding power source	ET 300i	EU
0445 100 920	Welding power source	ET 300iP	EU
0463 423 001	Spare parts list		
0463 424 001	Service manual		

Technical documentation is available on the Internet at www.esab.com

ACCESSORIES

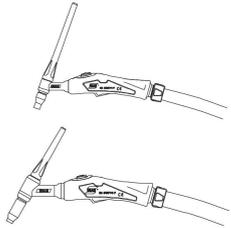
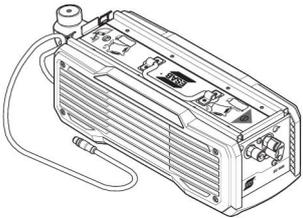
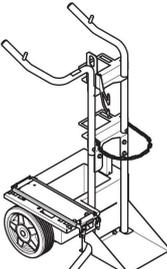
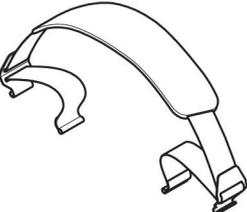
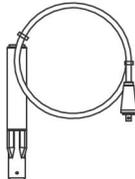
0700 300 538	TIG torch TXH™ 151, 4 m (13 ft)	
0700 300 544	TIG torch TXH™ 151, 8 m (26 ft)	
0700 300 552	TIG torch TXH™ 201, 4 m (13 ft)	
0700 300 555	TIG torch TXH™ 201, 8 m (26 ft)	
0700 300 855	TIG torch TXH™ 252w, 4 m (13 ft)	
0700 300 856	TIG torch TXH™ 252w, 8 m (26 ft)	
0700 300 565	TIG torch TXH™ 401w, 4 m (13 ft)	
0700 300 567	TIG torch TXH™ 401w, 8 m (26 ft)	
0445 045 880	EC 1000 Cooler	
0460 330 881	Trolley	
0445 197 880	Shoulder strap kit	
0700 006 902	Welding cable kit 3 meter, incl. electrode holder and OKC 50 connector	
0700 006 888	Welding cable kit 5 meter, incl. electrode holder and OKC 50 connector	
0700 006 903	Return cable kit 3 meter, incl. clamp and OKC 50 connector	
0700 006 889	Return cable kit 5 meter, incl. clamp and OKC 50 connector	
0160 360 881	OKC 50 male contact, pack 4 pcs	

ACCESSORIES

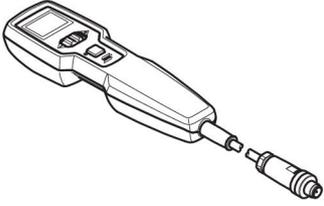
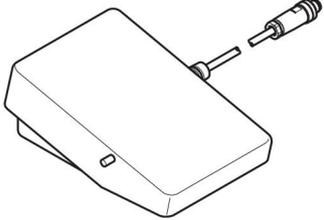
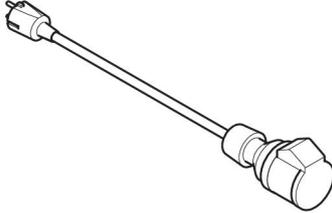
0445 536 881	ER 1 Remote control. 5 m (16.4 ft) interconnection cable, 6 pin, included.	
0445 536 882	ER 1 Remote control. 10 m (32.8 ft) interconnection cable, 6 pin, included.	
0445 536 883	ER 1 Remote control. 25 m (82 ft) interconnection cable, 6 pin, included.	
0445 280 880 0445 280 881 0445 280 882	Interconnection cable, 6 pin, 5 m (16.4 ft) Interconnection cable, 6 pin, 10 m (32.8 ft) Interconnection cable, 6 pin, 25 m (82 ft)	
0445 550 881	ER 1 F Foot pedal. 5 m (16.4 ft) interconnection cable, 6 pin, included.	
0445 550 882	ER 1 F Foot pedal. 10 m (32.8 ft) interconnection cable, 6 pin, included.	
0445 254 880 0445 254 881	Interconnection cable, 6 pin, 5 m (16.4 ft) Interconnection cable, 6 pin, 10 m (32.8 ft)	
0445 139 880	1 to 3 phase adapter Note! Only for use with Renegade ES 300i (0445 100 880), ET 300i (0445 100 900) and ET 300iP (0445 100 920)	

ESAB subsidiaries and representative offices

Europe

AUSTRIA

ESAB Ges.m.b.H
Vienna-Liesing
Tel: +43 1 888 25 11
Fax: +43 1 888 25 11 85

BELGIUM

S.A. ESAB N.V.
Heist-op-den-Berg
Tel: +32 15 25 79 30
Fax: +32 15 25 79 44

BULGARIA

ESAB Kft Representative Office
Sofia
Tel: +359 2 974 42 88
Fax: +359 2 974 42 88

THE CZECH REPUBLIC

ESAB VAMBERK s.r.o.
Vamberk
Tel: +420 2 819 40 885
Fax: +420 2 819 40 120

DENMARK

Aktieselskabet ESAB
Herlev
Tel: +45 36 30 01 11
Fax: +45 36 30 40 03

FINLAND

ESAB Oy
Helsinki
Tel: +358 9 547 761
Fax: +358 9 547 77 71

GREAT BRITAIN

ESAB Group (UK) Ltd
Waltham Cross
Tel: +44 1992 76 85 15
Fax: +44 1992 71 58 03

ESAB Automation Ltd
Andover

Tel: +44 1264 33 22 33
Fax: +44 1264 33 20 74

FRANCE

ESAB France S.A.
Cergy Pontoise
Tel: +33 1 30 75 55 00
Fax: +33 1 30 75 55 24

GERMANY

ESAB Welding & Cutting GmbH
Langenfeld
Tel: +49 2173 3945-0
Fax: +49 2173 3945-218

HUNGARY

ESAB Kft
Budapest
Tel: +36 1 20 44 182
Fax: +36 1 20 44 186

ITALY

ESAB Saldatura S.p.A.
Bareggio (Mi)
Tel: +39 02 97 96 8.1
Fax: +39 02 97 96 87 01

THE NETHERLANDS

ESAB Nederland B.V.
Amersfoort
Tel: +31 33 422 35 55
Fax: +31 33 422 35 44

NORWAY

AS ESAB
Larvik
Tel: +47 33 12 10 00
Fax: +47 33 11 52 03

POLAND

ESAB Sp.zo.o.
Katowice
Tel: +48 32 351 11 00
Fax: +48 32 351 11 20

PORTUGAL

ESAB Lda
Lisbon
Tel: +351 8 310 960
Fax: +351 1 859 1277

ROMANIA

ESAB Romania Trading SRL
Bucharest
Tel: +40 316 900 600
Fax: +40 316 900 601

RUSSIA

LLC ESAB
Moscow
Tel: +7 (495) 663 20 08
Fax: +7 (495) 663 20 09

SLOVAKIA

ESAB Slovakia s.r.o.
Bratislava
Tel: +421 7 44 88 24 26
Fax: +421 7 44 88 87 41

SPAIN

ESAB Ibérica S.A.
San Fernando de Henares
(MADRID)
Tel: +34 91 878 3600
Fax: +34 91 802 3461

SWEDEN

ESAB Sverige AB
Gothenburg
Tel: +46 31 50 95 00
Fax: +46 31 50 92 22

ESAB International AB

Gothenburg
Tel: +46 31 50 90 00
Fax: +46 31 50 93 60

SWITZERLAND

ESAB Europe GmbH
Baar
Tel: +41 1 741 25 25
Fax: +41 1 740 30 55

UKRAINE

ESAB Ukraine LLC
Kiev
Tel: +38 (044) 501 23 24
Fax: +38 (044) 575 21 88

North and South America

ARGENTINA

CONARCO
Buenos Aires
Tel: +54 11 4 753 4039
Fax: +54 11 4 753 6313

BRAZIL

ESAB S.A.
Contagem-MG
Tel: +55 31 2191 4333
Fax: +55 31 2191 4440

CANADA

ESAB Group Canada Inc.
Mississauga, Ontario
Tel: +1 905 670 0220
Fax: +1 905 670 4879

MEXICO

ESAB Mexico S.A.
Monterrey
Tel: +52 8 350 5959
Fax: +52 8 350 7554

USA

ESAB Welding & Cutting
Products
Florence, SC
Tel: +1 843 669 4411
Fax: +1 843 664 5748

Asia/Pacific

AUSTRALIA

ESAB South Pacific
Archerfield BC QLD 4108
Tel: +61 1300 372 228
Fax: +61 7 3711 2328

CHINA

Shanghai ESAB A/P
Shanghai
Tel: +86 21 2326 3000
Fax: +86 21 6566 6622

INDIA

ESAB India Ltd
Calcutta
Tel: +91 33 478 45 17
Fax: +91 33 468 18 80

INDONESIA

P.T. ESABindo Pratama
Jakarta
Tel: +62 21 460 0188
Fax: +62 21 461 2929

JAPAN

ESAB Japan
Tokyo
Tel: +81 45 670 7073
Fax: +81 45 670 7001

MALAYSIA

ESAB (Malaysia) Snd Bhd
USJ
Tel: +603 8023 7835
Fax: +603 8023 0225

SINGAPORE

ESAB Asia/Pacific Pte Ltd
Singapore
Tel: +65 6861 43 22
Fax: +65 6861 31 95

SOUTH KOREA

ESAB SeAH Corporation
Kyungnam
Tel: +82 55 269 8170
Fax: +82 55 289 8864

UNITED ARAB EMIRATES

ESAB Middle East FZE
Dubai
Tel: +971 4 887 21 11
Fax: +971 4 887 22 63

Africa

EGYPT

ESAB Egypt
Dokki-Cairo
Tel: +20 2 390 96 69
Fax: +20 2 393 32 13

SOUTH AFRICA

ESAB Africa Welding & Cutting
Ltd
Durbanville 7570 - Cape Town
Tel: +27 (0)21 975 8924

Distributors

For addresses and phone numbers to our distributors in other countries, please visit our home page

www.esab.com



www.esab.com

